

Our chain-stretcher sprockets with ball bearing are supplied "ready for mounting". They consist of a toothed wheel mounted on a ball bearing with double protection shield that guarantee a high resistance against break-age and wear. Bearing requires no maintenance.

The wheels are in C45 steel and they are toothed according to DIN 8187, ISO 606. The ball bearing can operate at a temperature from -20°C to $+120^{\circ}\text{C}$.

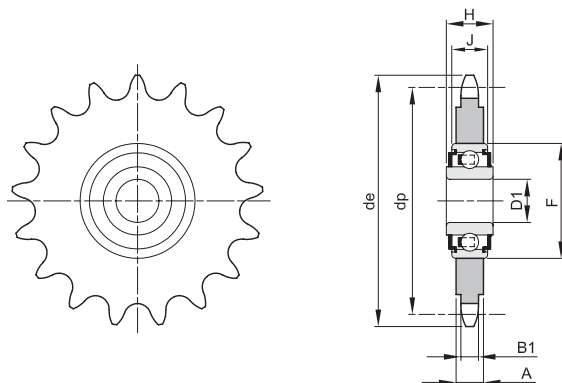

Материал C45 / Material C45

Z	pitch	ISO	De	Dp	B1	A	D1	F	H	J	Kg.
23 *	8 x 1/8"	05B-1	62,2	58,75	2,8	7,0	16 ^{+0,26} _{+0,13}	40	18,3	12	0,13
21 *	3/8" x 7/32"	06B-1	67,6	63,91	5,3	5,3	16 ^{+0,26} _{+0,13}	40	18,3	12	0,15
22	3/8" x 7/32"	06B-1	70,6	66,93	5,3	5,3	16 ^{+0,26} _{+0,13}	40	18,3	12	0,16
18 *	1/2" x 1/8"	081-1	79,4	73,14	3,0	7,0	16 ^{+0,26} _{+0,13}	40	18,3	12	0,18
15	1/2" x 3/16"	083-1	67,4	61,09	4,5	7,0	16 ^{+0,26} _{+0,13}	40	18,3	12	0,16
16	1/2" x 3/16"	083-1	71,4	65,10	4,5	7,0	16 ^{+0,26} _{+0,13}	40	18,3	12	0,17
18 *	1/2" x 3/16"	083-1	79,4	73,14	4,5	7,0	16 ^{+0,26} _{+0,13}	40	18,3	12	0,20
14	1/2" x 5/16"	08B-1	61,9	57,07	7,2	7,2	16 ^{+0,26} _{+0,13}	40	18,3	12	0,13
16 *	1/2" x 5/16"	08B-1	69,9	65,10	7,2	7,2	16 ^{+0,26} _{+0,13}	40	18,3	12	0,17
18 *	1/2" x 5/16"	08B-1	78,0	73,14	7,2	7,2	16 ^{+0,26} _{+0,13}	40	18,3	12	0,22
14 *	5/8" x 3/8"	10B-1	78,2	71,34	9,1	9,1	16 ^{+0,26} _{+0,13}	40	18,3	12	0,23
15	5/8" x 3/8"	10B-1	83,2	76,36	9,1	9,1	16 ^{+0,26} _{+0,13}	40	18,3	12	0,27
17 *	5/8" x 3/8"	10B-1	93,3	86,39	9,1	9,1	16 ^{+0,26} _{+0,13}	40	18,3	12	0,36
13 *	3/4" x 7/16"	12B-1	87,8	79,59	11,1	11,1	16 ^{+0,26} _{+0,13}	40	18,3	12	0,34
15 *	3/4" x 7/16"	12B-1	99,8	91,63	11,1	11,1	16 ^{+0,26} _{+0,13}	40	18,3	12	0,47
12 *	1" x 17,02	16B-1	109,7	98,14	16,2	16,2	20 ^{+0,10} ₋₀	47	17,7	14	0,72
13 *	1"1/4 x 3/4"	20B-1	147,7	132,67	18,5	18,5	25 ^{+0,10} ₋₀	52	21	15	1,64